

Four Sizes of Multiphase Progressing Cavity Pumps to Meet Customer Needs

Table is Representative Only.

Flow Rates are Speed Dependent, Discharge Pressure above those shown can be FACTORY REVIEWED.

Different Size Models can be utilized in various parallel configurations to closely match customer REQUIREMENTS.

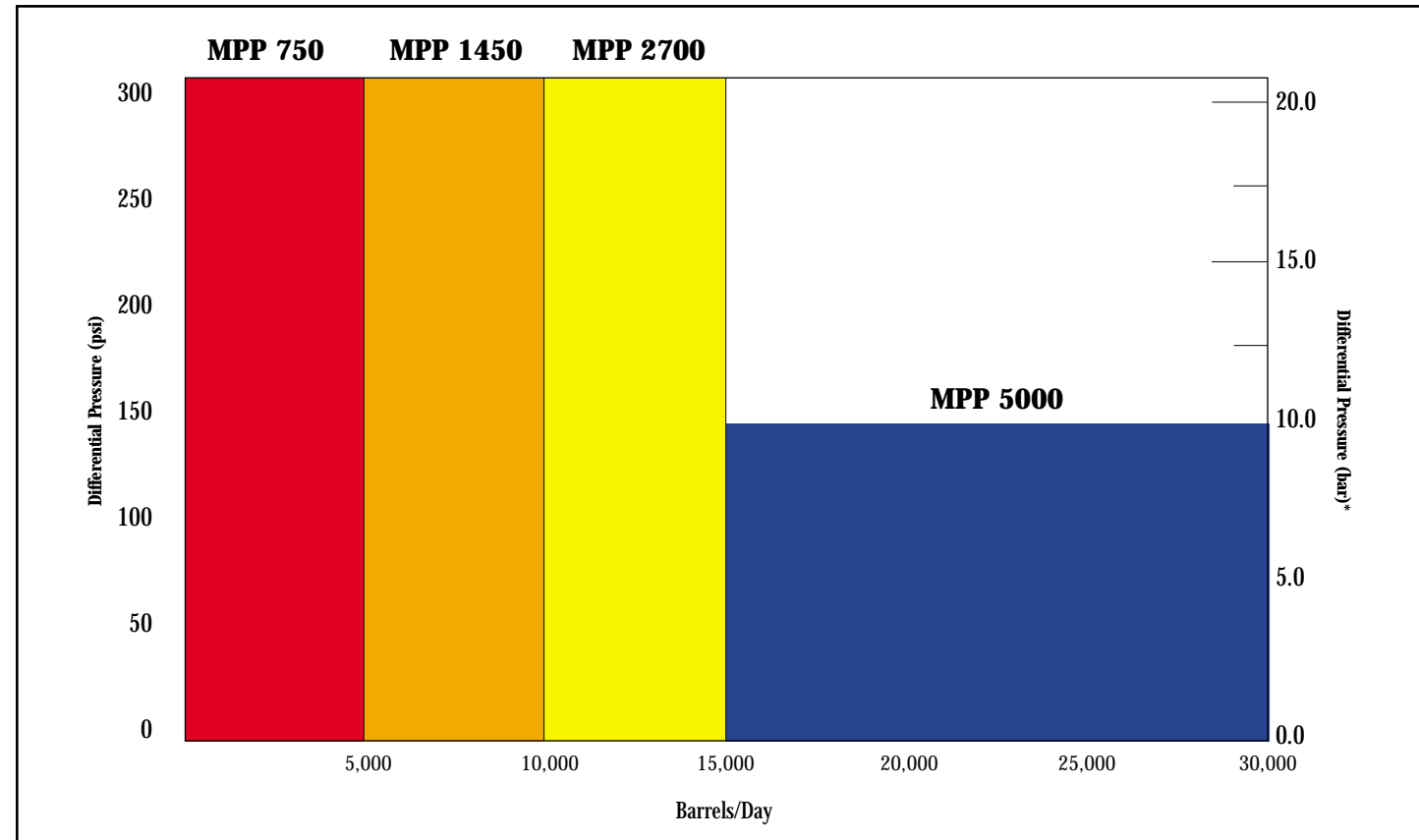

* Inlet suction pressures to 300 psig (21 barg).

Approximate Dimensions

PUMP SIZE	MOTOR HP	MOTOR FRAME	A	B	C	D	E	F	G	HL	J	K	L	M
750	75	365T	198.2"	194.2"	31.1"	21.5"	7.0"	7.5"	11.8"	50.4"	20.9"	33.4"	97.9"	9.8"
1450	100	405T	233.8"	229.8"	34.8"	23.6"	9.0"	8.5"	13.3"	66.0"	22.8"	38.3"	121.2"	11.0"
2700	150	445T	285.1"	281.1"	41.1"	29.9"	11.0"	9.8"	14.6"	28.5"	25.4"	44.6"	154.5"	14.7"
5000	150	445T	242.4"	238.4"	41.1"	29.9"	11.0"	9.8"	14.6"	40.2"	25.4"	44.6"	111.9"	14.7"

Dimensions not to be used for construction purposes.

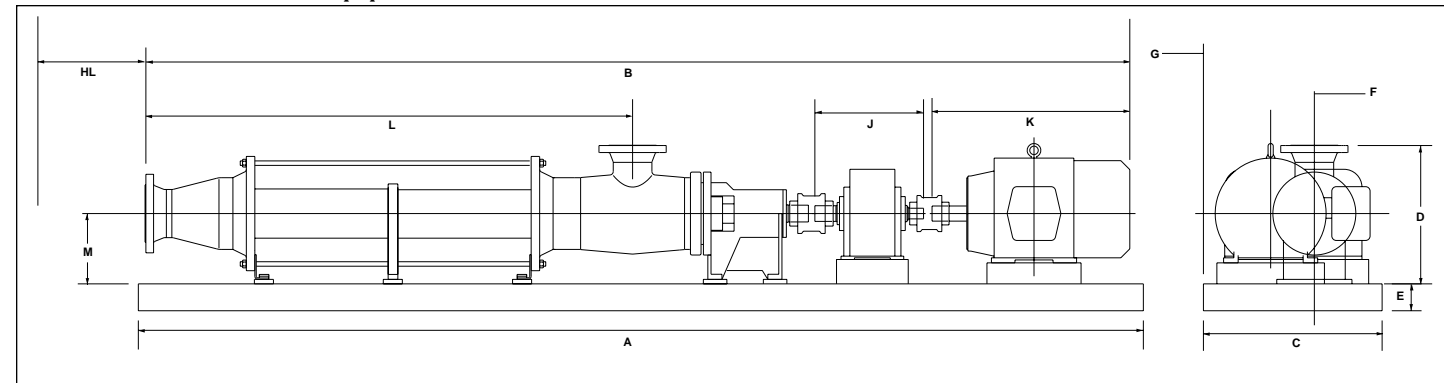

Warren Pumps
ALL-PHASE™ 1000 Series
 PC Multiphase Pumping Systems



ALL-PHASE™ 1000 Series PC Multiphase Pumping Systems

The All-Phase™ PC Multiphase Pumping System combines the superior design of Allweiler's progressive cavity pumps with Warren's engineering and market know-how. Our systems are capable of handling a wide range of flow conditions ranging from all gas to all liquid slugs. Each system is custom-built to customer specified well conditions and operating expectations. A customized control package ensures that the pump always operates at optimum performance.

Advantages

- Lowers wellhead pressure resulting in higher flow rates and increased production
- Handles high gas volume fractions and slugging (up to 100%)
- Significantly reduces up-front capital costs and lowers operating costs by eliminating the need for costly separation process
- Eliminates need for cooling units and separators
- Special elastomer formula combined with innovative hard coatings on rotors permit handling of high sand content
- Pumps can be connected in parallel
- Constant chamber volume provides non-pulsating flow
- Easily moved and reprogrammed to suit other well conditions
- Improves production performance in cyclic steam-flooding process

Standard Features

- Self-lubricated packing
- ANSI type flanges
- Stainless steel suction and discharge housing
- Fabricated steel base with drip rim
- Non-sparking guards
- Start-up assistance
- Variety of drive options

Sealing Options

- Seal with flushing system and monitoring device
- Cartridge mechanical seals
- Double mechanical seals



Simple or Complex System Packaging

ALLWEILER

